



EUROPEAN TOUCH™
The World's Finest Pedicure Spas



MURANO SPA™
OWNER'S MANUAL

European Touch – Limited Warranty

EUROPEAN TOUCH manufactures the Murano Spa with the highest standards for quality materials and workmanship accordingly; EUROPEAN TOUCH expressly warrants its products as follows:

To the original owner of the Murano Spa (herein called "pedicure spa"): EUROPEAN TOUCH may repair or replace, at its option, any pedicure spa found to be defective in material or workmanship upon inspection by an authorized representative of EUROPEAN TOUCH. This limited warranty covers the following components for the following time periods:

- All components: 18 months from date of shipment from manufacturer's facility.

The exchange of a pedicure spa is limited to supplying a replacement pedicure spa of comparable style and size. EUROPEAN TOUCH may, at its own discretion, use refurbished parts or pedicure spas for replacement purposes. Owner must pay all labor and shipping charges necessary to replace or repair the pedicure spa. NO CONSEQUENTIAL, INCIDENTAL, CONTINGENT, COMPENSATORY, INDIRECT, SPECIAL, OR OTHER DAMAGES WILL BE ALLOWED WHATSOEVER. This limited warranty is null and void if the pedicure spa is removed from its place of initial installation, or is not installed in accordance with the specifications of European Touch or federal, state or local codes and ordinances. Furthermore, this warranty does not apply if the pedicure spa has been subject to misapplication, improper installation or maintenance, negligence, improper cleaning or other circumstances beyond EUROPEAN TOUCH's control.

NOT COVERED:

1. Damage to pump parts and/or motor parts due to obstruction in plumbing lines, etc.
2. Staining, fading or discoloration of plastic surfaces due to exposure and/or the use of harmful cleaning agents or chemicals.
3. Staining, fading or discoloration caused by improper or poor water additives not related to maintenance of proper water are not covered by this warranty.
4. Malfunctions or damage caused by improper installation; including, but not limited to, failure to meet local and state plumbing, electrical, and building codes.
5. Staining, fading or discoloration of the vinyl seat, armrests, or footrest.
6. Damage resulting from standing in the basin.
7. Freight damage, misuse, modification, neglect, accident, natural disaster, and abuse.
8. Unauthorized repairs.
9. Damage while in possession of any party other than European Touch.

Should service be required for any reason of any defect or any malfunction during the warranty period, please contact:

EUROPEAN TOUCH
Technical Support
Toll-Free: 800-626-6912
Phone: 414-357-7016
Fax: 414-357-6360
service@europeantouch.com
<http://www.europeantouch.com>

The owner agrees by using this pedicure spa (a) that the obligation of EUROPEAN TOUCH shall not extend to indirect or contingent damages, or injury, which may result from such use and (b) that the obligations of EUROPEAN TOUCH are limited to those set forth herein. This limited warranty is the exclusive remedy and is in lieu of all other warranties, express or limited, including, but not limited to, any implied warranty of merchantability or fitness for a particular purpose. No dealer or other person has any authority to bind EUROPEAN TOUCH to changes or additions to this warranty or its products. Accordingly, EUROPEAN TOUCH is not responsible for any such warranties or representations.

OTHER PROVISIONS:

- This limited warranty is limited to the original owner/end-user and is not transferable.
- European Touch shall not be liable for any other obligations or liabilities, including, but not limited to, obligations or liabilities arising out of breach of contract or warranty, negligence, or other tort or any theory of strict liability with respect to the pedicure spa or the acts or omissions of European Touch.
- Any assistance European Touch provides to the original owner outside the terms, limitations or exclusions of this limited warranty will not constitute a waiver of search terms, limitations or exclusions, nor will such assistance extend or revive the warranty.

Inspection of the Murano Spa™

Inspect the Murano Spa™ and packaging. If any damage to the Murano Spa™ or its packaging is visible, please contact your local Murano Spa™ reseller or call European Touch Customer Support at 800-626-6912.

IMPORTANT INFORMATION

Serial Number: _____

Installed By: _____

Installation Date: _____

Serial Number Location

The serial number of your Murano Spa™ is needed when calling European Touch for any parts requests or warranty claims. It is located inside the left armrest door.



TABLE OF CONTENTS

INTRODUCTION.....	5
PRECAUTIONS.....	5
PRODUCT SPECIFICATIONS.....	6
MURANO SPA™ SPECIFICATIONS	6
IMPORTANT REQUIREMENTS	6
PLUMBING & CERTIFICATIONS.....	6
COMMONWEALTH OF MASSACHUSETTS PLUMBING & CERTIFICATIONS	6
INSTALLATION INSTRUCTIONS	8
ELECTRICAL SERVICE	8
WATER SUPPLY	8
DRAIN FACILITIES	8
LOCATION/POSITIONING	8
INSTALLING THE OUTER COVER	9
FEATURES OF THE MURANO SPA	10
GLASS BASIN.....	10
GLASS BASIN HEATER	10
CUSHIONED LEG SUPPORTS	10
CLIENT CHAIR	11
OPERATIONS GUIDE.....	12
POWER ON/OFF	12
WATER TEMPERATURE SETTING.....	13
BASIN UP AND BASIN DOWN	13
JETS PULSE.....	13
JETS HI/MED/LOW	13
AUTO FILL	13
AUTO DRAIN	13
AUTO CLEAN.....	14
FILLING THE MURANO SPA™	14
OPERATING THE CRYSTAL CLEAN™ WATER MOVEMENT SYSTEM.....	14
RAISING AND LOWERING THE BASIN	14
CLIENT CHAIR REMOTE CONTROL.....	15
BASIN SPRAYER	15
AIR RELAXATION SYSTEM	16
CLEANING INSTRUCTIONS.....	17
AFTER EVERY PEDICURE	17
AFTER THE LAST PEDICURE OF THE DAY	17
ONCE A WEEK OVERNIGHT CLEANING	17
TROUBLESHOOTING GUIDE.....	18
HISTORY AND NOTES.....	19



EUROPEAN TOUCH™

1-800-626-6912

Fax: 1-414-357-6360

etservice@europeantouch.com

info@europeantouch.com

www.europeantouch.com

Introduction

European Touch would like to thank you for your purchase of the Murano Spa™, the world's finest pedicure spa. From its beautifully crafted glass vestibule and sleek European styling to its technologically driven instrumentation and advanced cleaning standards, the Murano Spa™ system surpasses every industry standard for performance and comfort.

The Murano Spa™ console is designed to take away the guesswork and guarantee a professional stress-free pedicure. Every element of a healthy spa experience is directed at the push of a button. To take full advantage of all the functions provided by the Murano Spa™, please read through the operations guide starting on page 12.

With the Murano Spa™, you can also be assured of uncompromised cleaning standards with our patented Crystal Clean Pipe-Free™ technology, which replaces traditional-style jets and pipes that can harbor bacteria. The Crystal Clean Pipe-Free™ technology features a convenient, removable footplate to allow easy cleaning and features strategically placed grooves to provide a pleasing, relaxing water movement massage. To learn more about cleaning and maintaining your Murano Spa™, please refer to the cleaning instructions on page 17.

If you do experience any problems or have any questions regarding your Murano Spa™, please refer to the troubleshooting guide (found on page 18) or call 800-626-6912 to reach the Technical Support Department.



Precautions

- Do not stand in the basin of the pedicure spa!
- Excessive water temperature is dangerous and should be checked before use. Optimum operating water temperature should not exceed 105° F (41° C) and the maximum supply water temperature should not exceed 150° F (66° C).
 - *In the Commonwealth of Massachusetts; water temperature is not to exceed 130° F (54° C) max.*
- Always enter and exit the pedicure spa slowly and carefully, with basin in down position.
- Never bring or operate any electrical devices into or near the pedicure spa.
- This pedicure spa has a weight capacity of 350 pounds (158.8kg).

Product Specifications

Murano Spa™ Specifications

- **Overall dimensions with seat back, glass basin raised and seat in full recline:** 75"L (190cm) x 32"W (82cm) x 43"H (109cm)
- **Empty Weight:** 353lbs. (137kg)
- **Shipping Weight:** 536lbs (174 kg) Ships fully assembled except for the outer cover.
- **Capacity of Tub:** 5 U.S. Gallons
- **Power Source:** 120V AC/15Amp, 60HZ (dedicated circuit, GFCI Protected)
- **Construction:** Glass Reinforced Polyester (GRP) frame covers, steel frame
- **Glass Basin:** Borosilicate glass; Impact resistant, thermal shock resistant, scratch resistant, chemical and stain resistant.
- **Glass Basin Dimensions:** 25.5" L X 24.5"W X 9"H.
- **Crystal Clean Pipe-Free™ Whirlpool System:** 14 “underfoot” footplate water-massage grooves, no closed loop circulating pipes, 100% fully drained and cleanable.

Important Requirements

European Touch requires that you contact a local, licensed plumber and licensed electrician to install your new pedicure spa. Installation must be in compliance with all your local and state building codes. Your pedicure spa cannot operate efficiently or safely unless it is provided with adequate electrical power, sufficient water pressure, proper water temperature, and required drainage capabilities. Contact your local building inspector for information and local code compliance procedures that need to be followed when having your pedicure spa installed. Subsequent inspections and approvals that may be required are the responsibility of the purchaser. (See **limited warranty regarding incidental or consequential exclusions – page 2**).

Plumbing & Certifications

- Hot & Cold water supply lines required. The Murano Spa “tail” contains the hot & cold water supply hoses and the drain hose. The hoses are ½” ID hoses that are 24" long from the back of the Murano Spa. The connection is ½” female hose fitting. The maximum supply water temperature must not exceed 150°F (65°C). *See Commonwealth of Massachusetts for local specifics below.*
- Compliant with IAPMO plumbing standards.
- Compliant with ASME standards A112.18.3 for backflow protection and A112.9 for water retention.
- The Murano Spa has been designed with the latest technology plumbing components, which are approved to ASSE, IAPMO, and NSF standards.

Commonwealth of Massachusetts Plumbing & Certifications

- All plumbing must be installed by a plumber licensed by the commonwealth of Massachusetts.
- All plumbing products shall be in compliance with the Commonwealth of Massachusetts State Fuel & Gas plumbing codes CMR 248; 1.00-7.00 as amended.
- All plumbing installations shall include back flow protection devices in compliance with CMR 248, Massachusetts State Plumbing Code.
 - *Water temperature not to exceed 130 °F (54 °C) max.*

NOTE 1: All specifications are subject to change without notice.

NOTE 2: All dimensions are approximate.

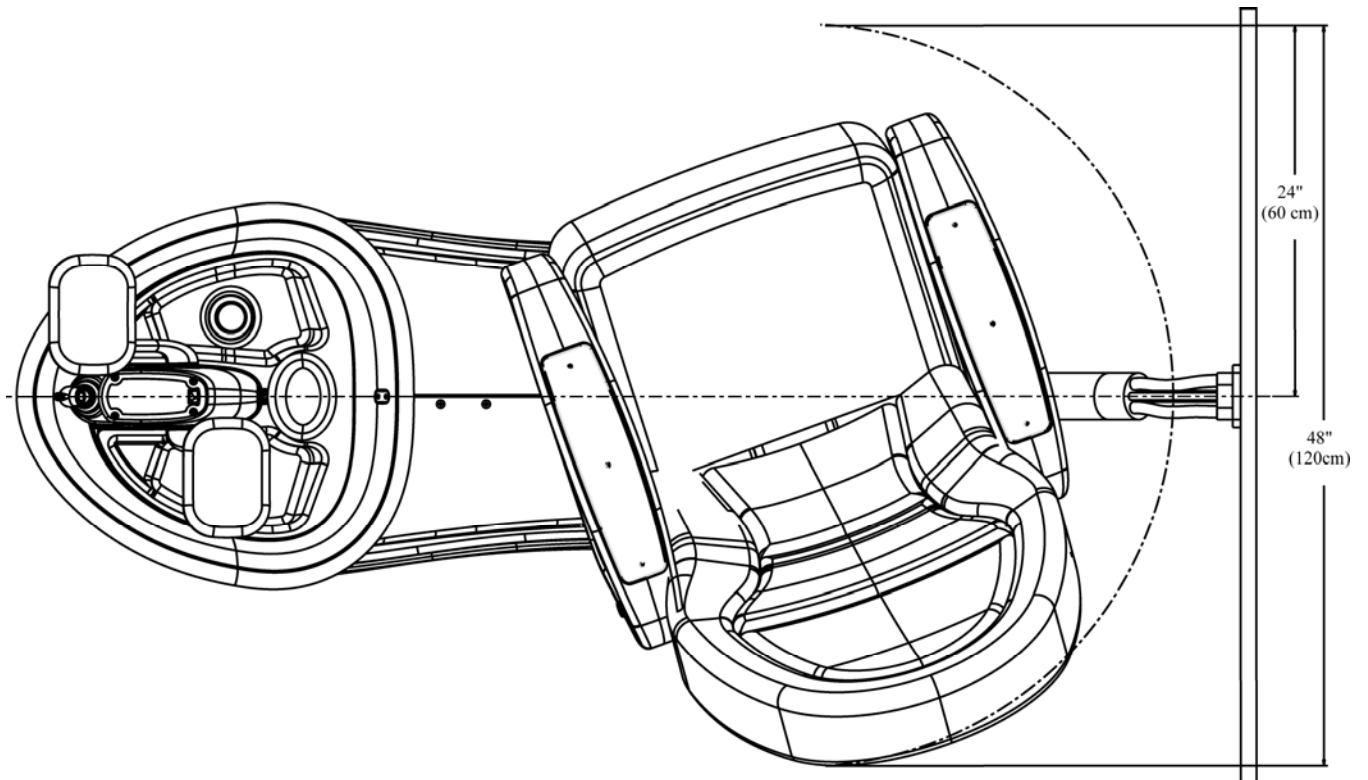
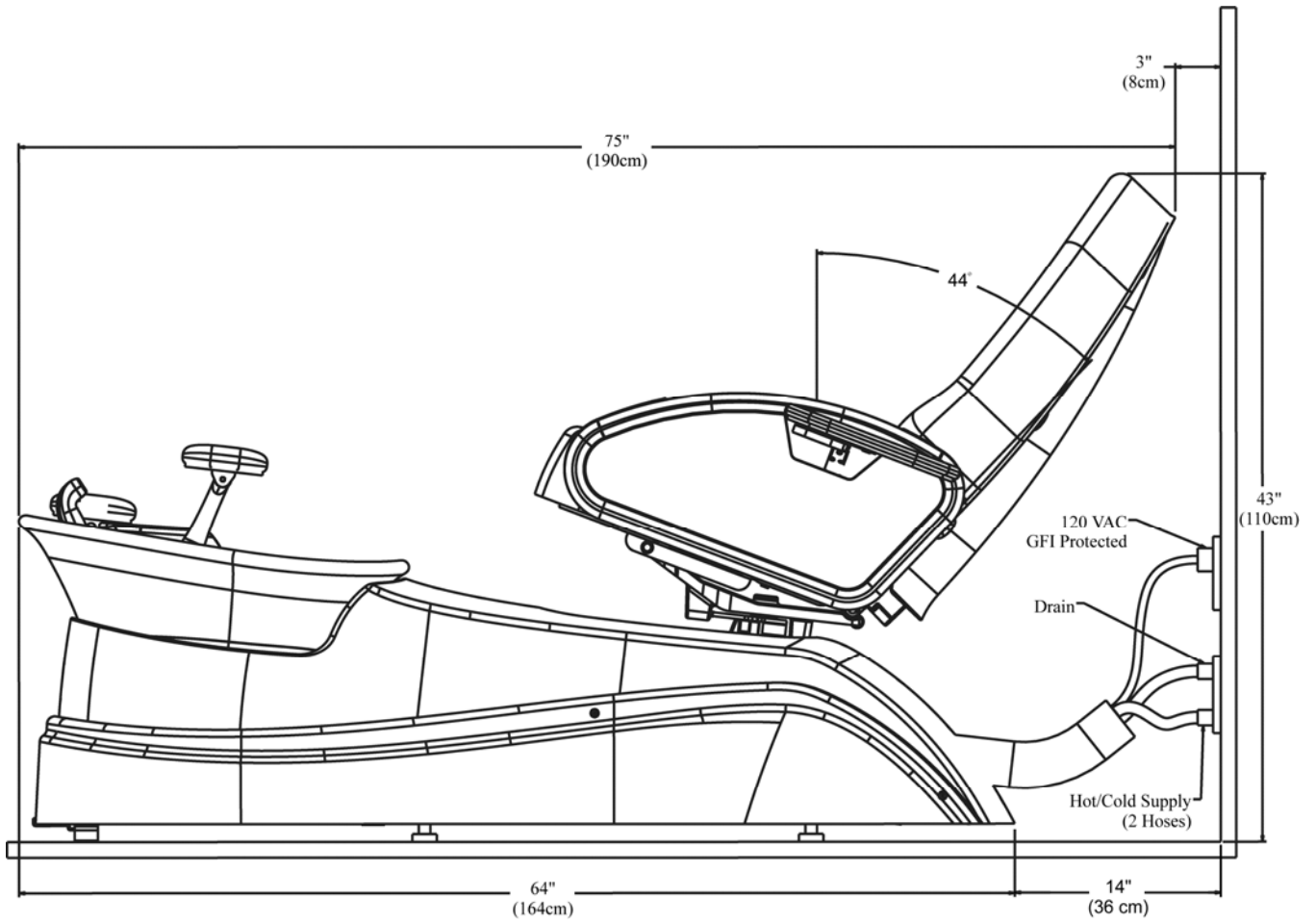

Installation Instructions

The Murano Spa™ installation must comply with all plumbing and electrical codes. A licensed plumber and licensed electrician must complete the applicable connections of the pedicure spa.

Electrical Service

- A 110V, 60 Hz, 15 Amp GFCI protected grounded circuit must be used to supply power to the Murano Spa.

Water Supply

- All plumbing connections must conform to state and local codes.
- Normal water pressure of 30 to 60 P.S.I. is required to correctly fill the tub to the proper level.
- The hot water supply temperature must not exceed 150° F (65° C). Adjust your hot water heater accordingly.
 - *In the Commonwealth of Massachusetts; water temperature is not to exceed 130° F (54° C) max.*
- Carefully connect the incoming water supply lines to the appropriate hose located on the back of the Murano Spa. Shut-off valves are highly recommended.
- The Murano Spa comes equipped with backflow protection on the mixing valve to meet ASME standard A112.18.3.

Drain Facilities

The Murano Spa comes equipped with a power drain pump. The discharge hose is located at the back of the Murano Spa. The drain hook-up must meet local plumbing codes.

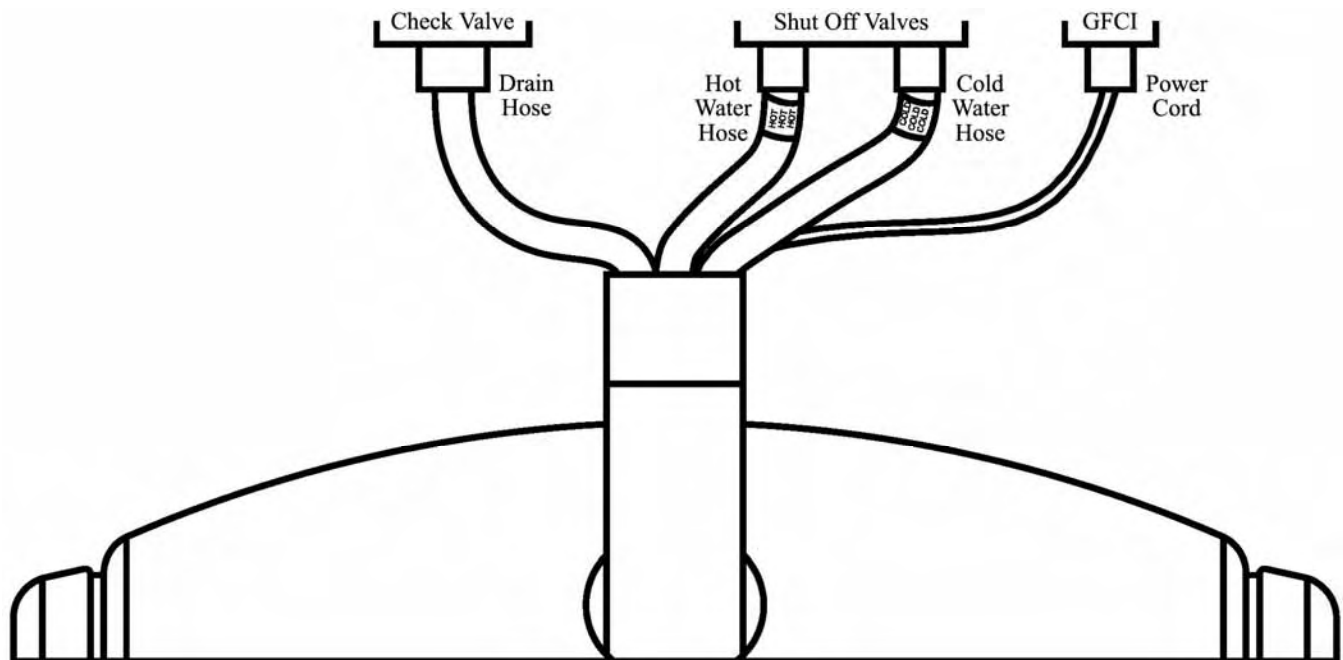

Location/Positioning

The Murano Spa™ is designed to be installed and operated on a level surface. For optimal performance, ensure the intended location of use is level before installing the unit. Also ensure the adequate proximity of the plumbing and electrical supply locations as shown in the drawings on page 7.

Installing the Outer Cover

Carefully slide the outer cover around the outside of the Murano Spa™. The covers will spread wide enough to fit around the back legs.



The outer cover is connected to the spa with 4 Phillips head screws (included). Make sure that the front notch of the cover is on the front cover mounting bracket.

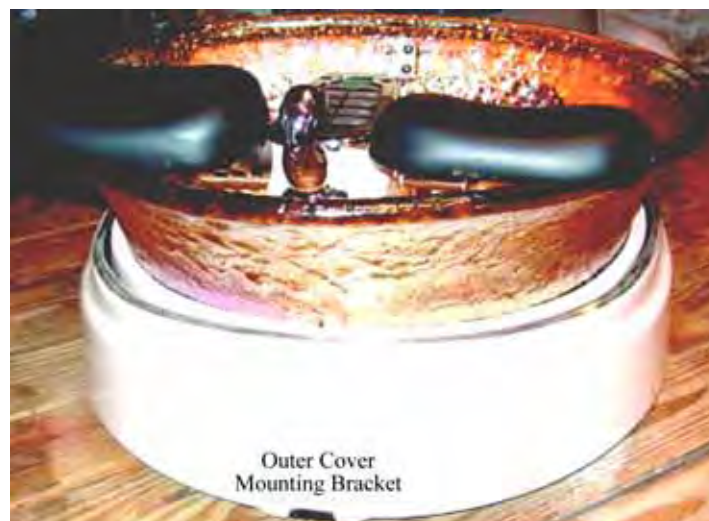

Features of the Murano Spa

Glass Basin

The glass basin has been designed to enhance the beauty of your salon. The smooth textured glass finish is durable, bacteria resistant, and easy to clean. The glass basin is designed for easy cleaning using the sprayer and an EPA approved disinfecting cleaner. Please read the recommendations on the cleaning product before using it in the spa to make sure that it is safe on glass products. Call European Touch Technical Support at 800-626-6912 with any questions regarding the cleaning of your Murano Spa™.

Glass Basin Heater

The glass basin has a heater conveniently built in to it to help maintain the water temperature. The heater is turned on once the basin starts filling with water. The heater will cycle as needed to help maintain the water temperature within two degrees of the set temperature.

Cushioned Leg Supports

The cushioned leg supports are set to lock in the full up position or full forward. The cushions are contoured for added comfort. The leg supports are designed for easy cleaning using an EPA approved disinfecting cleaner. Optional terry cloth footrest covers are available for purchase (one complimentary set of terry cloth covers ARE included with your Murano Spa™ purchase).

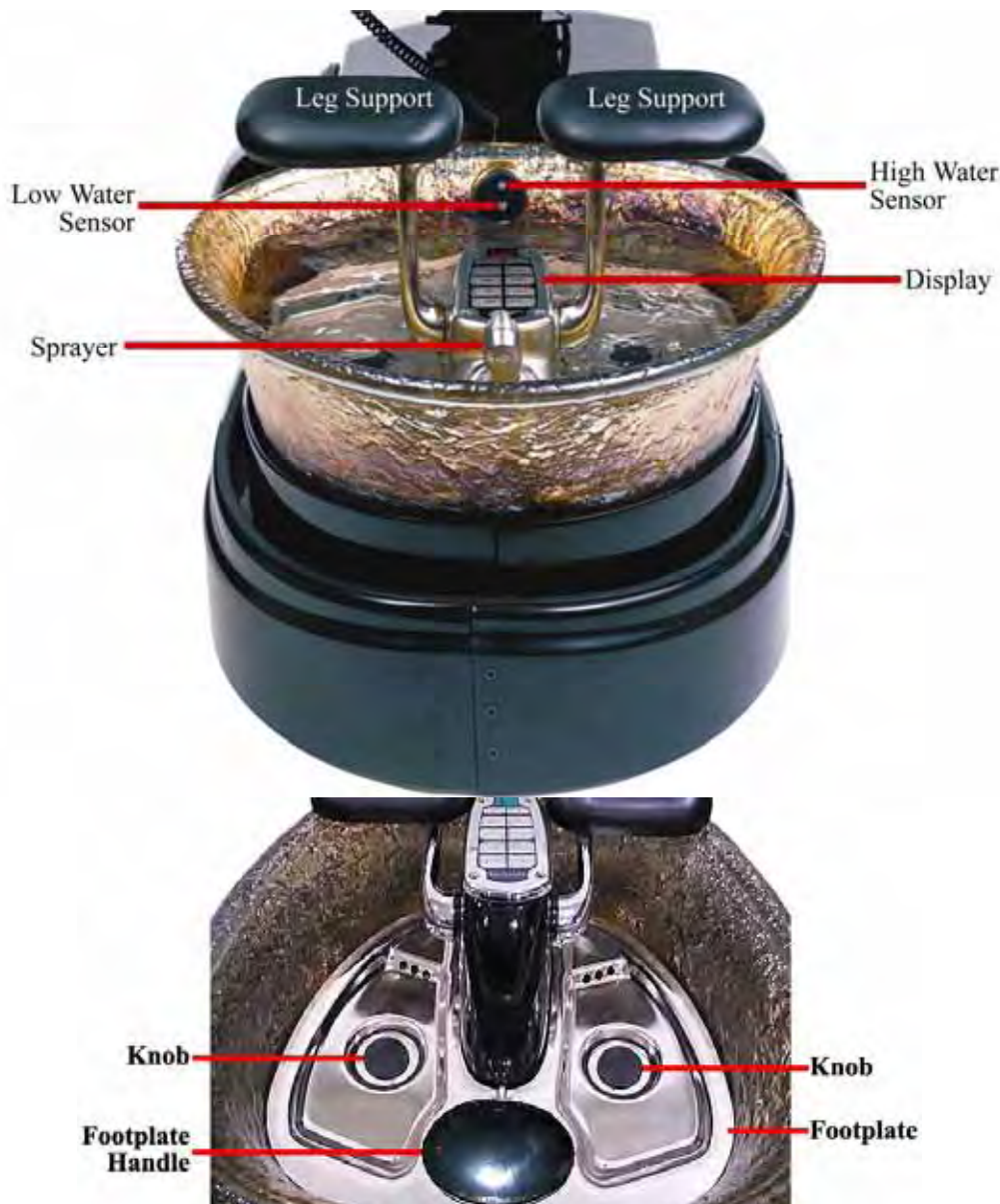

Client Chair

The chair has been designed to hold up to 350lbs. The extra-wide chair swivels to both sides for ease of entry and exit. The chair can also tilt forward to assist customers. Before cleaning the client chair, read the product label prior to use and test on a small area on the back of the cushion first.



Operations Guide

Power on/off

- a. To turn the power on to the Murano Spa™, simply push the “On/Off” button. The display will turn on and read “105” (if set in ° Celsius, the display will show “40”).
- b. When the power is turned on, you might hear a quiet motor noise for a few seconds. This is the electronic faucet turning on.
- c. To turn the power off to the Murano Spa™, simply push the “On/Off” button. The display will read “- - -” for a few seconds, then go blank.
- d. With the power turned off, none of the Murano Spa™ functions will work, with the exception of the basin and chair movements. This includes: air relaxation system, faucet and sprayer, and any console operations.



Water Temperature Setting

- a. The “+” and “-” buttons below the display control the water temperature setting. The water can be set from 80° F (26° C) to 115° F (46° C).
- b. The default setting is 105° F. To set the water temperature between 106° F (41° C) and 110° F (43° C), hold the “+” button for 5 seconds and the temperature display will start to increase. To increase the water temperature from 111° F (44° C) to 115° F (46° C), hold the “+” button for 10 seconds and the temperature display will start to increase. To decrease the water temperature, press and hold the “-” button until you reach the desired temperature.
- c. If the temperature is below the desired setting, the Murano Spa™ will automatically drain some of the water out and replace it with hot water. The Murano Spa™ will repeat these steps until the desired temperature has been reached or 10 attempts.

Basin Up and Basin Down

- a. “Basin Up” controls the upward travel of the glass basin. The basin movement will automatically stop once it reaches the maximum height.
- b. “Basin Down” controls the downward travel of the glass basin. The basin movement will automatically stop once it reaches the full down position.

Jets Pulse

- a. When this button is pushed, the Crystal Clean Water Movement System will start on high speed and cycle between high, medium and low speed.
- b. To turn this off, simply press the “Jets Pulse” button or “Jets Hi/Med/Low” button.

Jets Hi/Med/Low

- a. Pressing this button will turn the Crystal Clean Water Movement System on high speed. The display will read “SP3”.
- b. Keep pressing this button to choose medium speed (SP2), low speed (SP1) and to turn the Crystal Clean Water Movement System off.

Auto Fill

- a. Press this button to fill the basin with water. The Water Temperature setting will control the temperature of the incoming water.
- b. The water will automatically turn off once the water reaches the lower water level sensor.
- c. Any time the “autofill” function is enabled, the Murano Spa™ will continue to drain a small amount of water and refill the basin with warmer or cooler water in order to maintain the set temperature to within 2° F as needed.

Auto Drain

- a. To drain the water from the Murano Spa™, push the “Auto Drain” button. The Murano Spa™ will take 14 seconds to start draining the water from the glass basin.
- b. To stop the drain cycle, push the “Auto Drain” button.
- c. When the Murano Spa™ is in the drain cycle, the display will show “drn”.
- d. If there is water in the Murano Spa™ and the power is turned off (standby mode), the Murano Spa™ will automatically turn on, go into the Auto Drain cycle, then turn back off.

Auto Clean

- a. “Auto Clean” can be set for Clean 1 (end of day cleaning) or Clean 2 (end of the week cleaning). Holding the “Auto Clean” button will switch it between the different clean cycles.
- b. Once the Auto Clean cycle is started, all of the function buttons on the console are turned off except for the Power on/off button.
- c. See cleaning instructions on page 17.

Filling the Murano Spa™

Once the plumbing and electrical connections have been made, you are ready to test your Murano Spa™.

1. Turn the power “on” to the Murano Spa™ by pressing the “On/Off” button on the console.
 - a. You will hear a motor noise, this is the electronic faucet assembly powering up.
2. The LED display will automatically read “105”. This is the default water temperature setting. Pressing the “+” and “-” buttons will adjust the water temperature setting.
3. Once the desired temperature is set, push the “Auto Fill” button. The green light will turn on next to the “Auto Fill” button, “FIL” will appear on the display, and the basin will start to fill with water. The basin fills from underneath the footplate. **Note: The Murano Spa™ will not fill unless the footplate is securely fastened to the basin.**
4. The water will automatically shut off once the water level reaches the low water sensor.

Operating the Crystal Clean™ Water Movement System

1. Turn the Crystal Clean Water Movement System on by pressing the “Jets Hi/Med/Low” button. The jets will turn on high speed and the display will show “SP 3”. Pressing the “Jets Hi/Med/Low” button again will switch the speed to medium and the display will show “SP 2”. Pressing the “Jets Hi/Med/Low” button again will switch the speed to low and the display will show “SP 1”. Pressing the “Jets Hi/Med/Low” button again will turn the jets off and the display will read “OFF”.
2. Press the “Jets Pulse” button, the jets will turn on high speed, then slow down to low speed. The Crystal Clean Water Movement System will continue to cycle the water speed between high and low speed until “Jets Pulse” or “Jets Hi/Med/Low” buttons are pushed.

***Note: The Crystal Clean™ Water Movement System will automatically turn off if the “Auto Drain” or “Power On/Off” buttons are pushed.**

Raising and Lowering the Basin

1. Raise the basin by pushing and holding the “Basin Up” button. The basin will stop automatically at the fully raised position or when you release the “Basin Up” button. Make sure that the water begins to drain when the water level reaches the upper water sensor. **Note: There is a slight delay before the drain will start to drain water from the basin.**
2. Lower the basin by pushing and holding the “Basin Down” button. The basin will automatically stop once it reaches the full down position or when you release the “Basin Down” button. If the water level drops below the lower water sensor, the Murano Spa™ will automatically start to fill the basin until the water level reaches the lower water sensor.

Client Chair Remote Control

1. Swivel the chair completely to the left or to the right until it reaches the detent. The chair will hold in place.
2. Push the “Tilt Forward” button on the chair remote control. The chair will tilt forward. The chair will automatically stop when tilted full forward or when you release the “Tilt Forward” button. *Note: This feature allows easy entry and exit to the chair for clients who are in need of extra assistance.*
3. Push the “Recline” button on the remote control. The chair will recline backwards. The chair will automatically stop when fully reclined or when you release the “Recline” button.
4. Push the “Slide Forward” button on the chair remote control. The chair will move forward, towards the basin. The chair will automatically stop when full forward or when you release the “Slide Forward” button.
5. Push the “Slide Back” button on the chair remote control. The chair will move backwards, away from the basin. The chair will automatically stop when full back or when you release the “Slide Back” button.
6. Push the “Jets Hi/Med/Low/” button on the chair remote control. The Crystal Clean Water Movement System will turn on high speed and the display on the console assembly should read “SP 3”. Each time you press the “Jets Hi/Med/Low” button will switch the speed on the Crystal Clean Water Movement System from high, to medium, to low, and off.
7. Push the “Jets Pulse” button on the chair remote control. The Crystal Clean Water Movement System will work in the pulse mode.

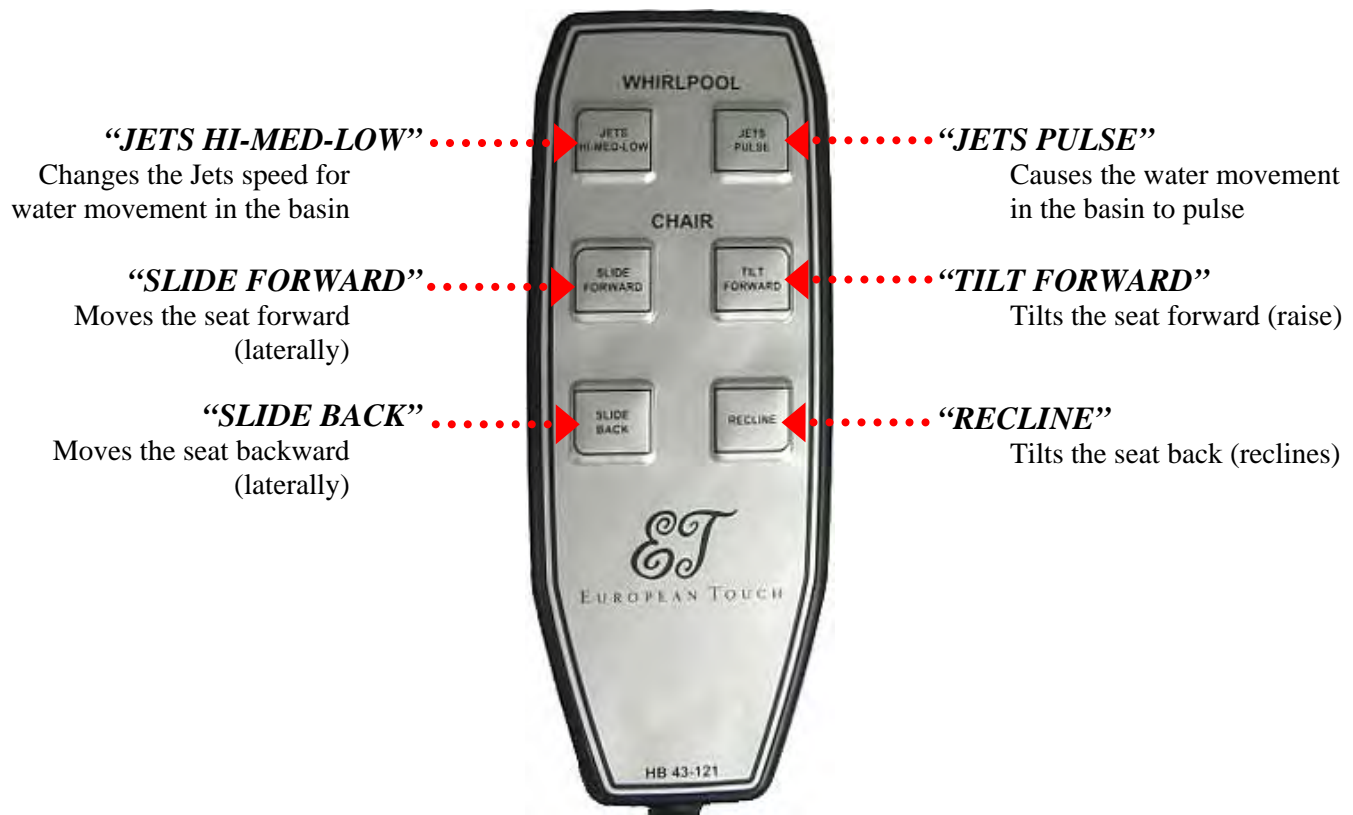

Basin Sprayer

1. The basin sprayer is ready to use whenever the Murano Spa™ power is turned on. The sprayer water will be at the temperature shown on the display.
2. When using the sprayer to clean out the basin and footplate, you may need to press the “Auto Drain” button to drain the basin.

Air Relaxation System

Turning On\Off

1. Press POWER button to turn ON.
2. Repeat Step #1 to turn OFF.

Inflate\Deflate Pillows for a Customized Massage

1. Press SELECT button.
2. Choose any combination of ZONES 1-3 by pressing button(s).
3. INFLATE\DEFLATE massage pillow(s) by pressing and holding corresponding button.

Selecting Massage Type

1. First, choose area of back (lower, middle, upper) desiring massage by pressing any one, or combination of, ZONES 1-3.
2. Choose between PULSE or WAVE by pressing button.

Selecting Massage Mode Cycle Time

1. Choose between SHORT, MEDIUM or LONG cycles by pressing CYCLE button.

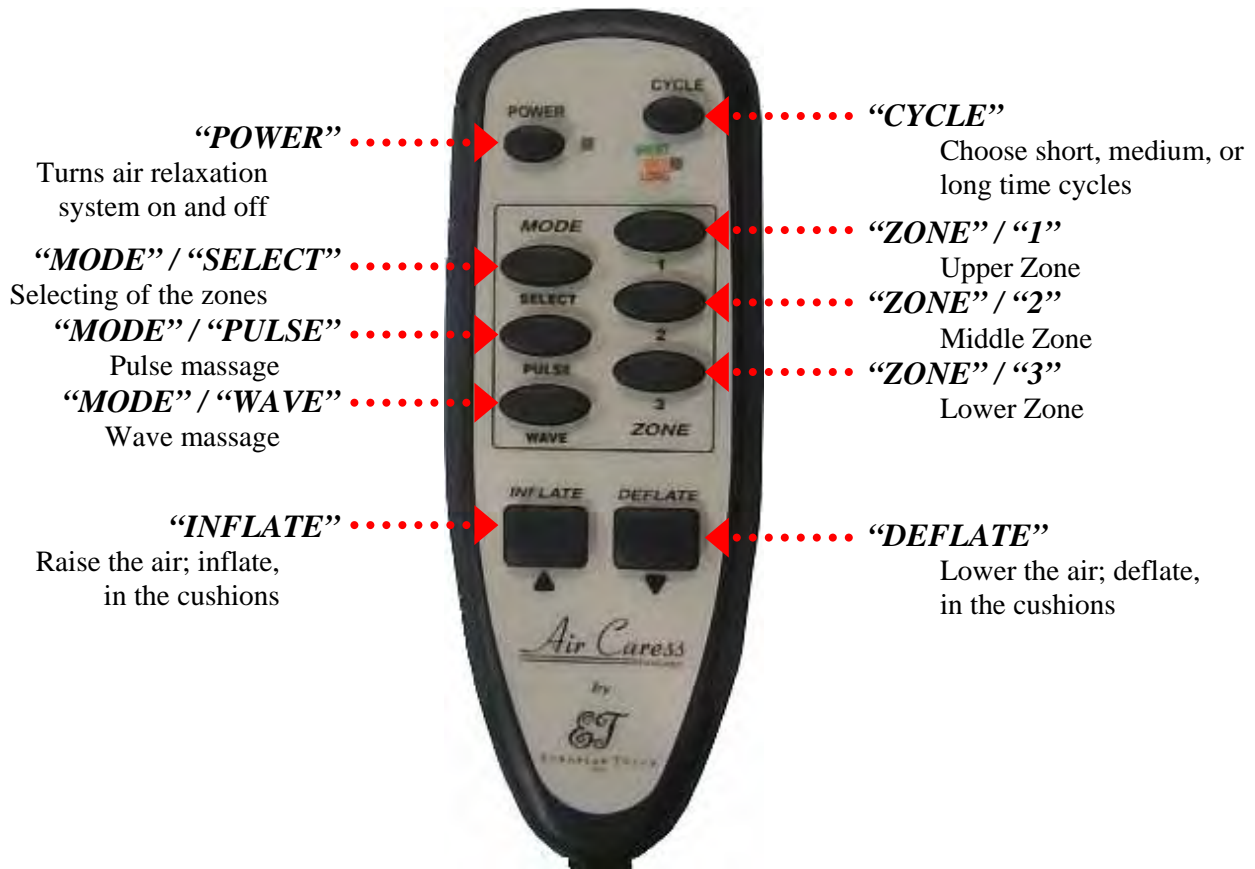

***Note: The Air Relaxation System is pre-programmed to run for 15 minutes and cannot be adjusted. To turn the system back on after it turns off, press the “Power” button and select the desired operating mode.**

Cleaning Instructions

The Murano Spa™ has been designed to be easily and quickly disinfected in between each customer. The design of the Crystal Clean Water Movement System ensures that the entire whirlpool system is disinfected completely in just a few quick minutes when the following instructions are followed.

Always refer to your state and local guidelines for cleaning requirements.

After every pedicure

1. Drain the spa by pressing the “Auto Drain” button.
2. Remove the footplate by unscrewing the 2 mounting knobs.
3. Lift the footplate and rinse the basin, footplate and all of the components inside the basin using the sprayer. You may need to press the “Auto Drain” button to drain the water out of the spa.
4. Thoroughly spray the basin, footplate and all of the components inside the basin with an EPA - registered disinfectant, in accordance with your State Board requirements. **EPA disinfectants require ten-minute contact.*
5. Thoroughly wipe the basin, footplate and all of the components inside the basin dry using a clean towel.
6. Place the footplate back into the basin and secure to the glass basin using the 2 mounting knobs.

After the last pedicure of the day

1. Follow the **After Every Pedicure** cleaning instructions.
2. Press the “Auto Clean” button. The display will show “CLN 1”.
3. The spa will fill for 30 seconds, then drain. This will rinse the footplate and bottom of the basin.
4. The spa will automatically fill to the fill sensor. The display will show “SANI-SCRUB” and the “Auto Clean” light will blink.
5. Pour **three teaspoons** of Low-foaming dishwasher crystals (not gel) and 1 ounce of household bleach into the basin and press the “Auto Clean” button.
6. The spa will run for 10 minutes. The display will count down from 600 seconds.
7. The spa will automatically drain, and then fill with clean water.
8. The spa will run for 1 minute. The display will count down from 60 seconds.
9. The spa will automatically drain. Once the spa finishes the drain cycle it will turn the power off.

Once a week overnight cleaning

1. Follow the **After Every Pedicure** cleaning instructions.
2. Press and hold the “Auto Clean” button. The display will toggle between “C-1” and “C-2”. Release the button when the display shows “C- 2”.
3. The spa will fill for 30 seconds, then drain. This will rinse the footplate and the bottom of the basin.
4. The spa will automatically fill to the fill sensor. The display will show “SANI-SCRUB” and the “Auto Clean” light will blink.
5. Pour **three teaspoons** of Low-foaming dishwasher crystals (not gel) and 1 ounce of household bleach into the basin and press the “Auto Clean” button.
6. The spa will run for 1 minute, and then turn off.
7. The spa will let the water sit in the basin for 6 hours.
8. After 6 hours, the spa will turn on for one minute, then automatically drain and fill with clean water.
9. The spa will run for run for 1 minute. The display will count down from 60 seconds.
10. The spa will automatically drain. Once the spa finishes the drain cycle it will turn the power off.

Note: Cleaning products containing harsh abrasives should be avoided as they could damage the finish on the pedicure basin and components.

Troubleshooting Guide

Any “E” code can be reset by holding down the “on/off” button for ten (10) seconds. If code comes back reference the troubleshooting guide below.

PROBLEM	DESCRIPTION	BASIC TROUBLESHOOTING
E01 error code	Communication problem with the EAU	Reset display by holding down “On/Off” button for 5 seconds Check interconnection cable (Mini-DIN is seated properly) Upgrade display unit with software revision C or later.
E06 error code	Communication error with Water information from EAU.	Reset display by holding down “On/Off” button for 5 seconds Check interconnection cable (Mini-DIN is seated properly) Upgrade display unit with software revision C or later.
E07 error code	Water too cold for EAU (45°F / 7°C)	Ensure basin water temperature is above 45°F (7°C) Reset display by holding down “On/Off” button for 5 seconds Check basin sensor
E08 error code	Water too hot for EAU (135°F / 57°C)	Ensure basin water temperature is below 135°F (57°C) Reset display by holding down “On/Off” button for 5 seconds Check basin sensor
E09 error code	Overflow error (in standby, otherwise it displays “Hi H2O”)	Ensure water level is below the overflow sensor Reset display by holding down “On/Off” button for 5 seconds
E10 error code	Water too cold for gearbox (45°F)	Ensure water supply temperature is above 45°F (7°C) Reset display by holding down “On/Off” button for 5 seconds Check valve sensor
E11 error code	Water too hot for gearbox (135°F)	Ensure water supply temperature is below 135°F (57°C) Reset display by holding down “On/Off” button for 5 seconds Check valve sensor
E12 error code	Communication error with gearbox	Reset display by holding down “On/Off” button for 5 seconds Check interconnection cable (Mini-DIN is seated properly)
“Clean Sensor” message	Error with water detection sensors	Clean basin water level sensors with alcohol & soft cloth Press “Auto Fill” to resume operation
Display reads “40” instead of “105”	°C is displayed instead of °F	Turn off the spa by pressing the “On/Off” button Press and hold the “On/Off” button until the desired temperature reading is displayed, then release.
Won’t function	Electrical problem with unit	Ensure power supply outlet is working (press GFI reset) Check EAU circuit breaker (press reset button)
Water leak	Water found on floor that was not caused by splashing during pedicure	Try to identify source of leak Call European Touch Customer Support at 800-626-6912
Drain motor continues to run	Water not draining properly. Water between sensor and drain hole.	Ensure basin is thoroughly clean Ensure Murano Spa™ is installed on level surface
Basin/Chair Movement	Basin/Chair movement does not respond to controls	Ensure power supply outlet is working (press GFI reset) Ensure spa is turned on at console display
Swivel catches or moves slowly	Spring plunger adjusted improperly or not greased	Adjust spring plunger Apply lithium grease to swivel plate
Air massage controls not working	Possible loose connection	Ensure spa is turned on at console display Ensure handset is on Ensure compressor is on
Basin does not fill	Water does not fill into the basin “no plt” message	Ensure footplate is properly inserted and fastened Ensure spa is turned on at console display Ensure water is supplied on both hot and cold supply hoses
Basin does not drain	Water does not drain from the basin	Ensure power supply outlet is working (press GFI reset) Remove and clean drain plunger Ensure drain line is not plugged or restricted

If the problem could not be resolved with the use of this troubleshooting guide, please call European Touch Technical Support at 1-800-626-6912

History and Notes

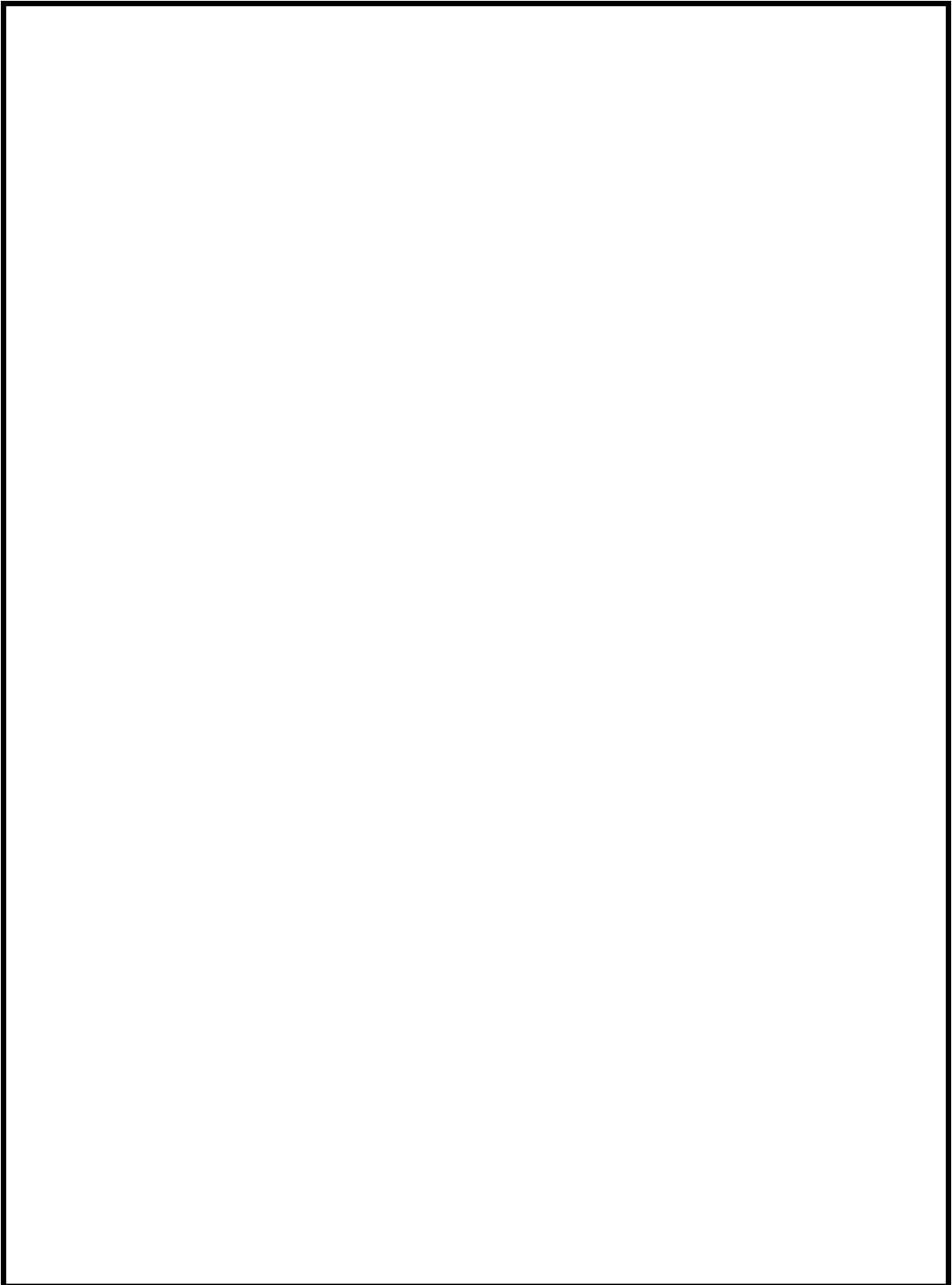



EUROPEAN TOUCH™

***European Touch
8301 W Parkland Court
Milwaukee, WI 53223***

***1-800-626-6912
Fax: 1-414-357-6360***

***info@europeantouch.com*
*etservice@europeantouch.com***

www.europeantouch.com